

Bruggenfamilies

presentatie | webinar

24 maart 2022

inleiding

Waarom een bruggenfamilie?

- een eenduidige vormgeving van objecten, bruggen draagt bij aan de beeldkwaliteit in een gebied (wijk, gemeente, stadsdeel, etc.)
- voordelig voor voorbereiding van realisatie van bruggen; voordeel tijdbesteding / kosten; ontwerp, engineering, aanbesteding, welstand, procedures, etc.

bruggenstandaard Alphen a/d Rijn

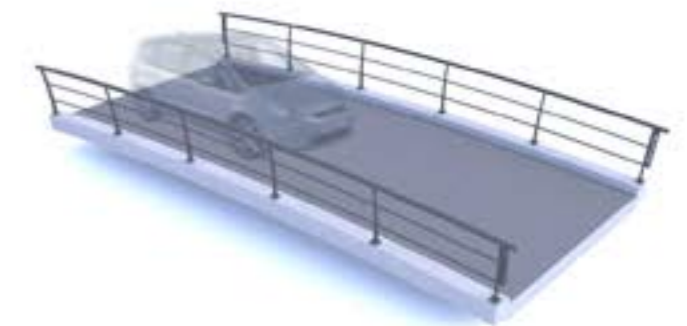
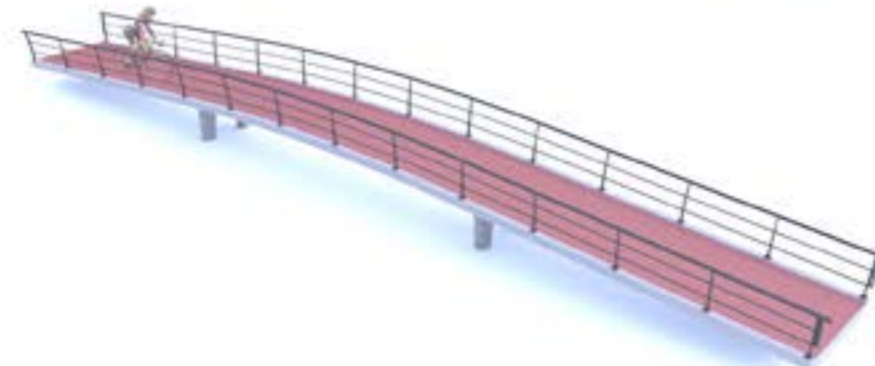

bruggenstandaard Alphen a/d Rijn > uitgangspunten

vervangingsopgaven jaren 80 bruggen

Doel bruggenstandaard;

- zelf aanbestedingen uitvragen met de bruggenstandaard
- eenduidig brugtype, detaillering > beheer & onderhoud

bruggenstandaard Alphen a/d Rijn

FUNCTIE BRUG

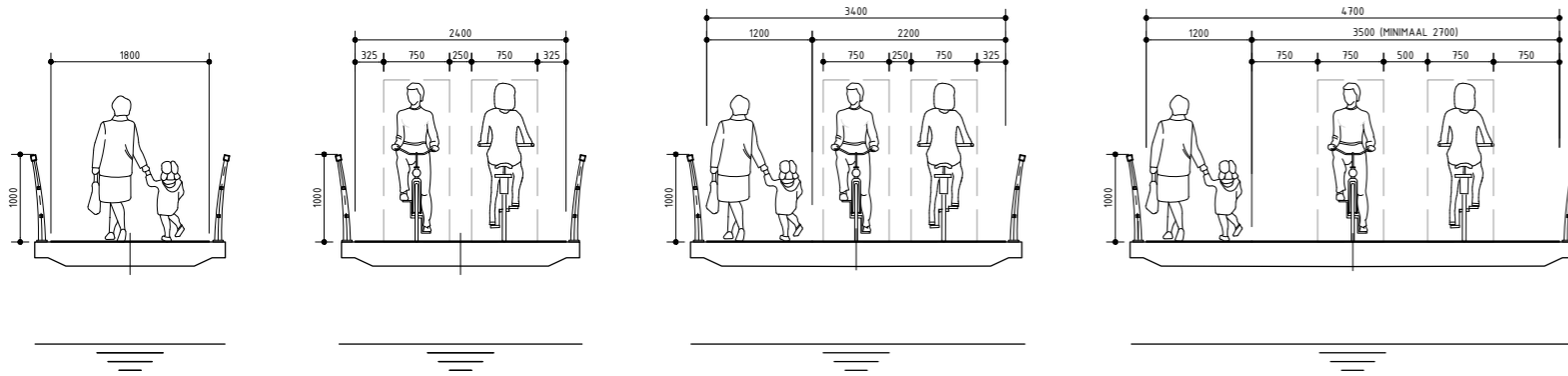

1. VOETGANGERSBRUG 2. VOETGANGERS-, FIETSBRUG 3. VOETGANGERS-, FIETSBRUG MET LOSSE VOETGANGERSSTROOK 4. VOETGANGERS-, FIETSBRUG MET LOSSE VOETGANGERSSTROOK, HOGE INTENSITEIT

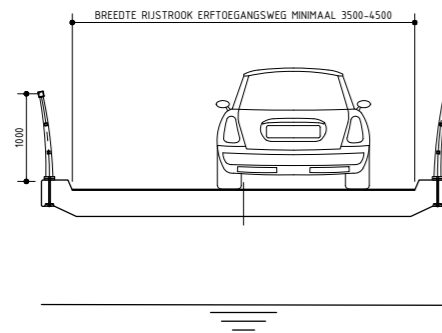

5. VERKEERSBRUG ZONDER VOETGANGERSSTROOK

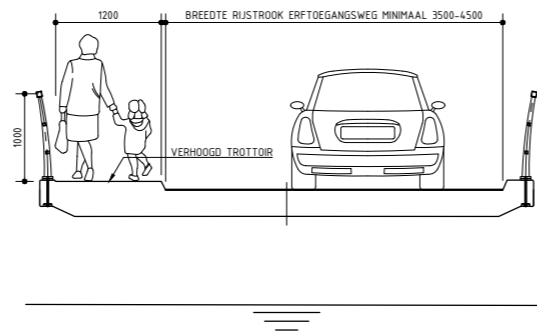

6. VERKEERSBRUG MET VOETGANGERSSTROOK

MATERIAAL EN OPBOUW BRUGCONSTRUCTIE

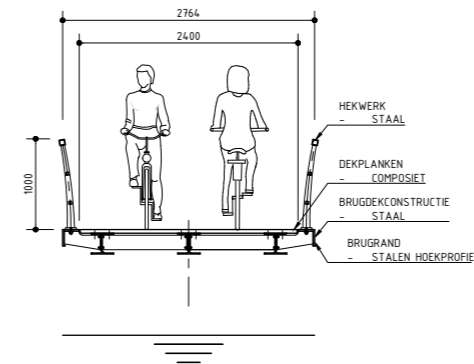

VOORBEELD DOORSNEDEN BRUGDEKCONSTRUCTIE - STAAL

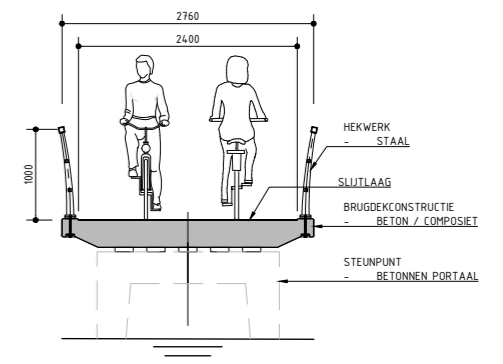

VOORBEELD DOORSNEDEN BRUGDEKCONSTRUCTIE - BETON OF COMPOSIEET

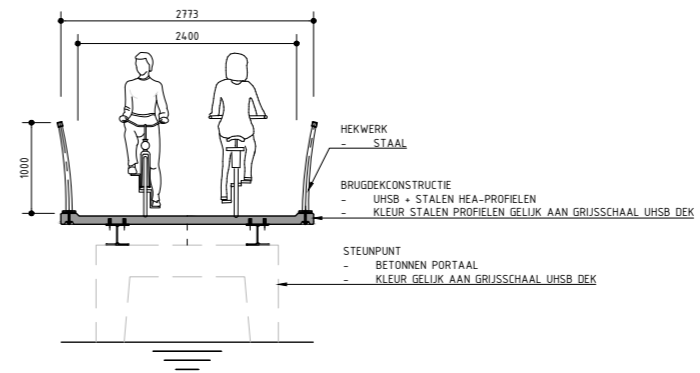

VOORBEELD DOORSNEDEN BRUGDEKCONSTRUCTIE - UHSB + STALEN LIGGERS

bruggenstandaard Alphen a/d Rijn

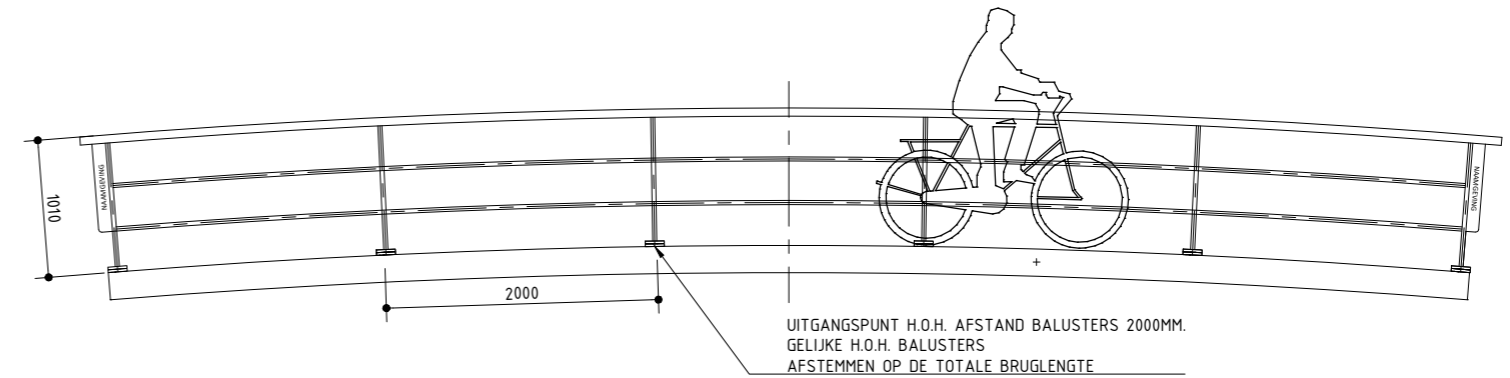

HEKWERK TYPE LANDELIJK

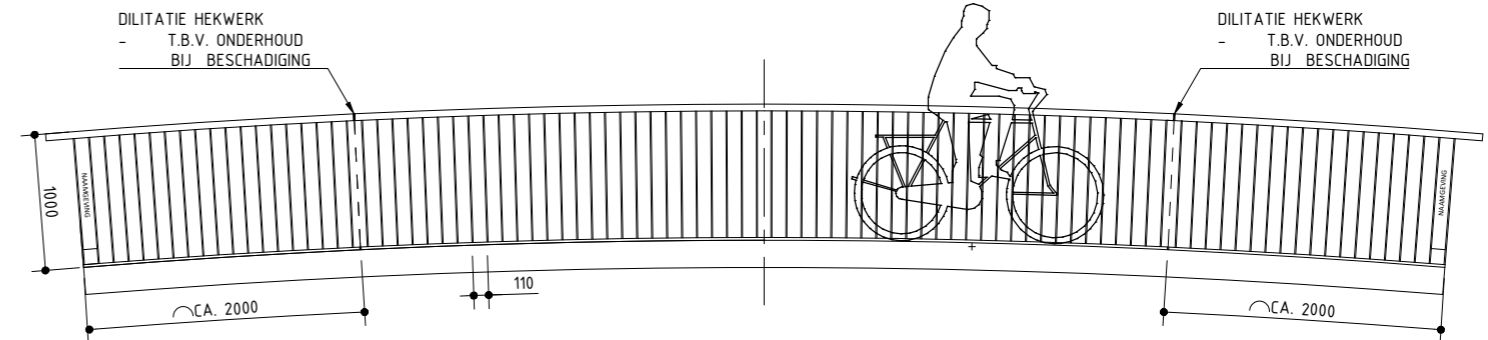

HEKWERK TYPE STEDELIJK

bruggenstandaard Alphen a/d Rijn

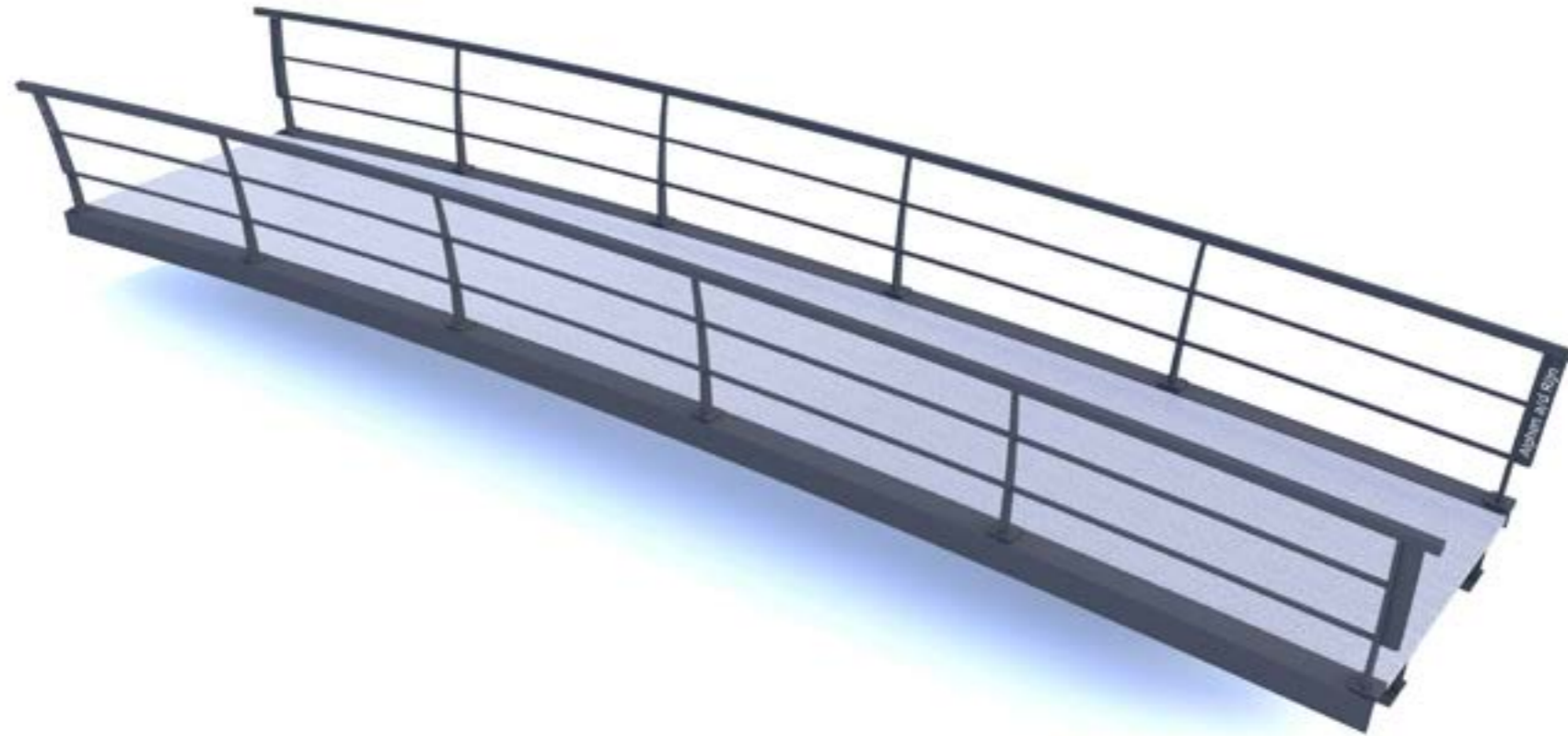

bruggenstandaard Alphen a/d Rijn

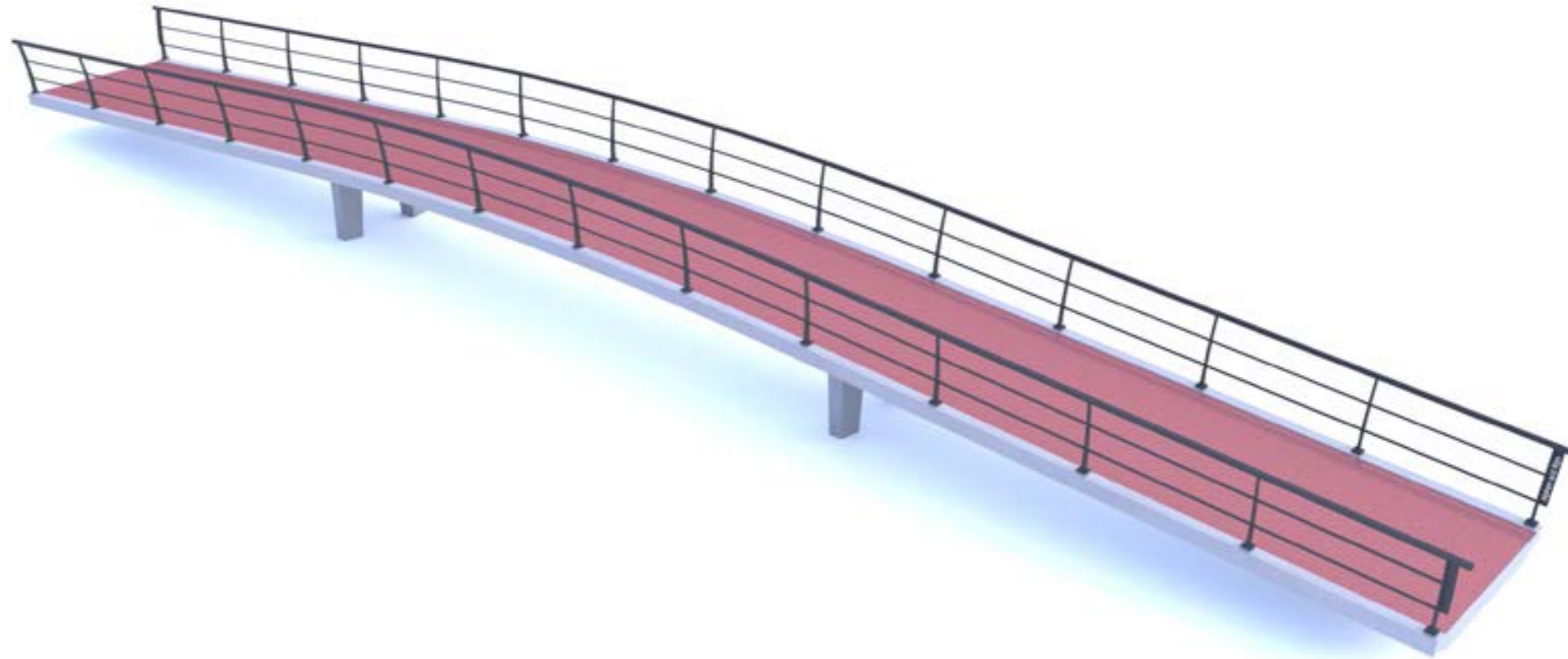

bruggenstandaard Alphen a/d Rijn

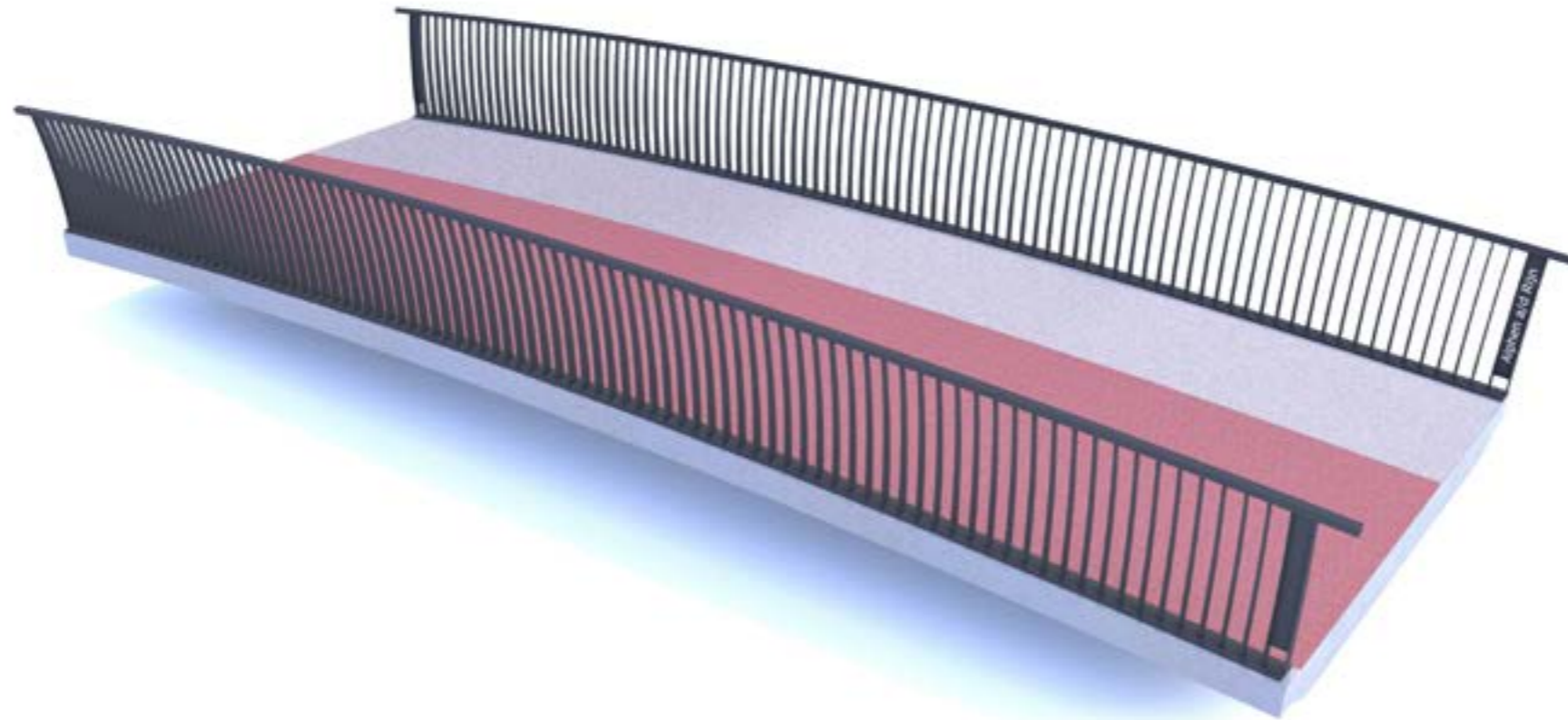

bruggenstandaard Alphen a/d Rijn



bruggenstandaard Alphen a/d Rijn



bruggenstandaard Alphen a/d Rijn



bruggenstandaard Alphen a/d Rijn



bruggenstandaard Alphen a/d Rijn > composite structures



kunstwerken Noordwaard



kunstwerken Noordwaard

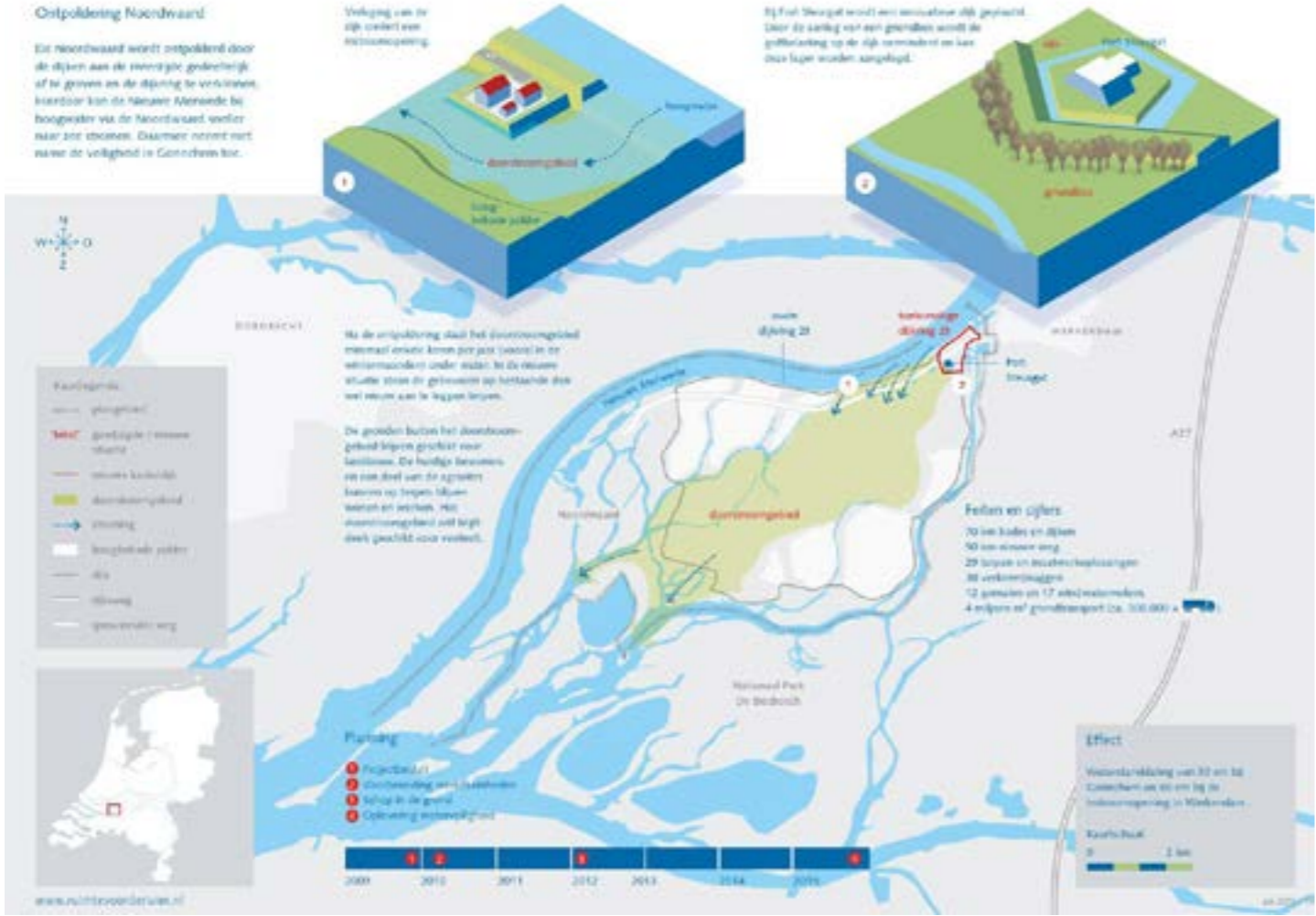

kunstwerken Noordwaard



kunstwerken Noordwaard

Waterpeil 0,40 - 0,70 NAP



1,40 - 2,00 NAP

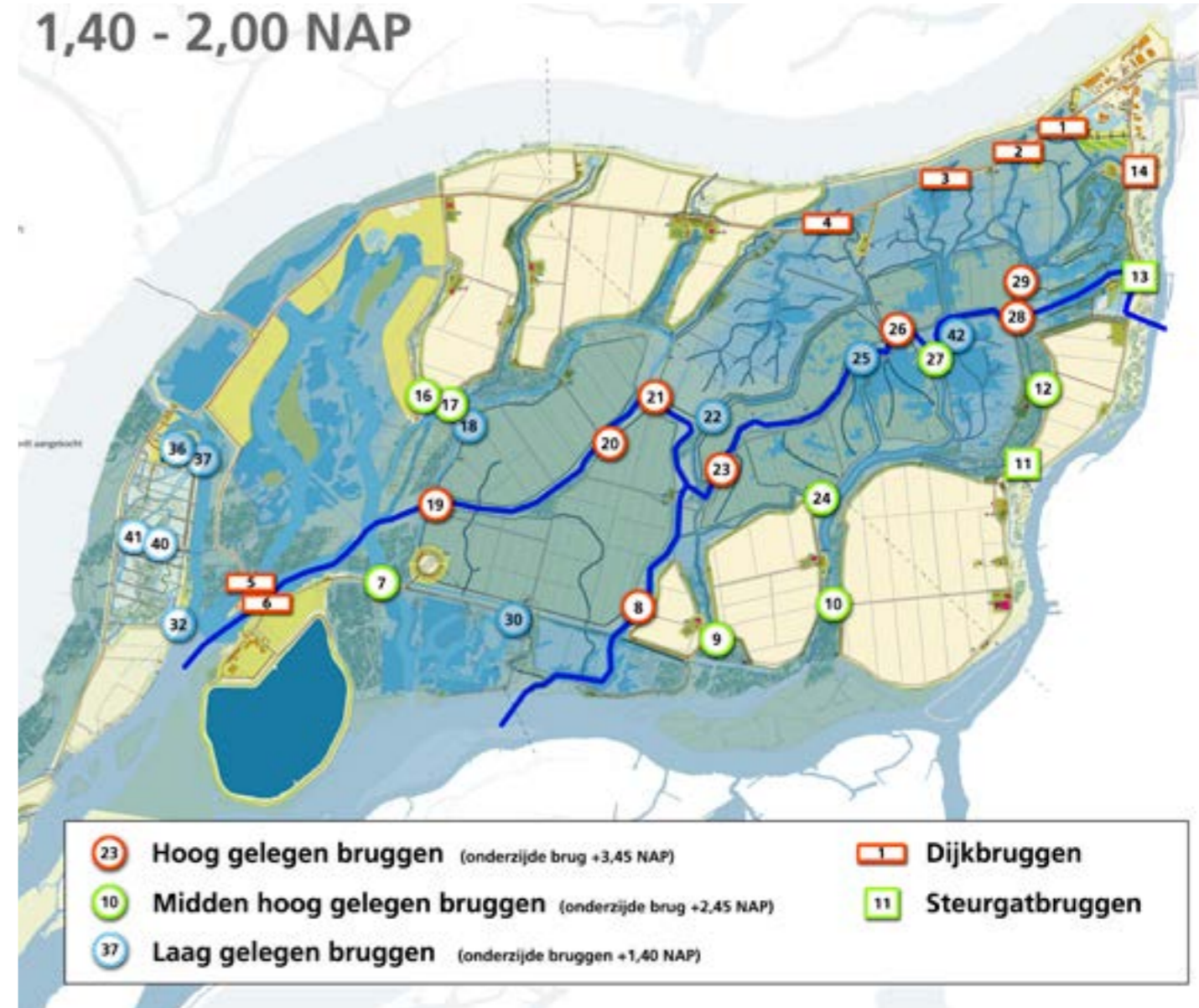

kunstwerken Noordwaard

Waterpeil 0,40 - 0,70 NAP

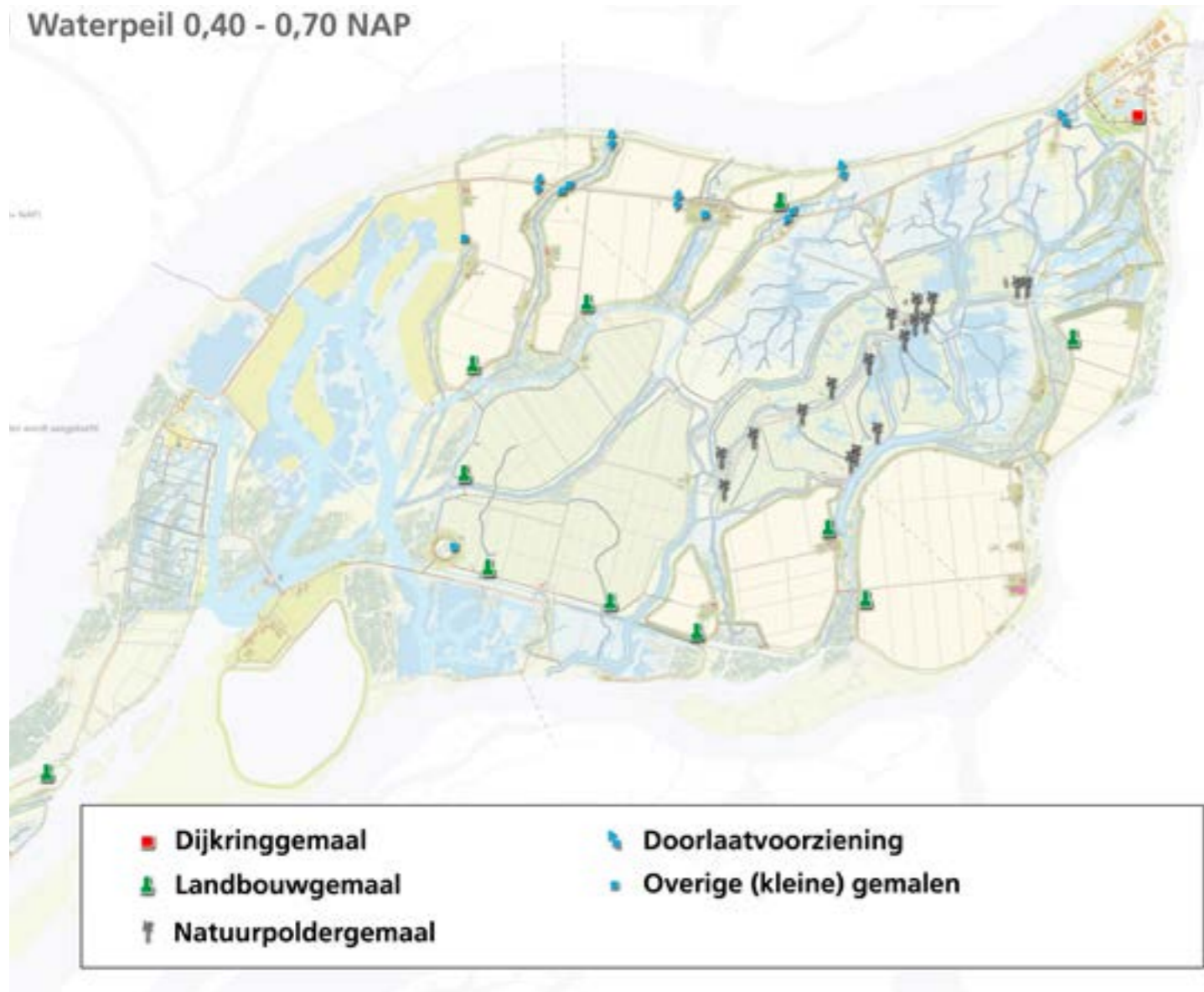

Waterpeil 0,70 - 1,40 NAP

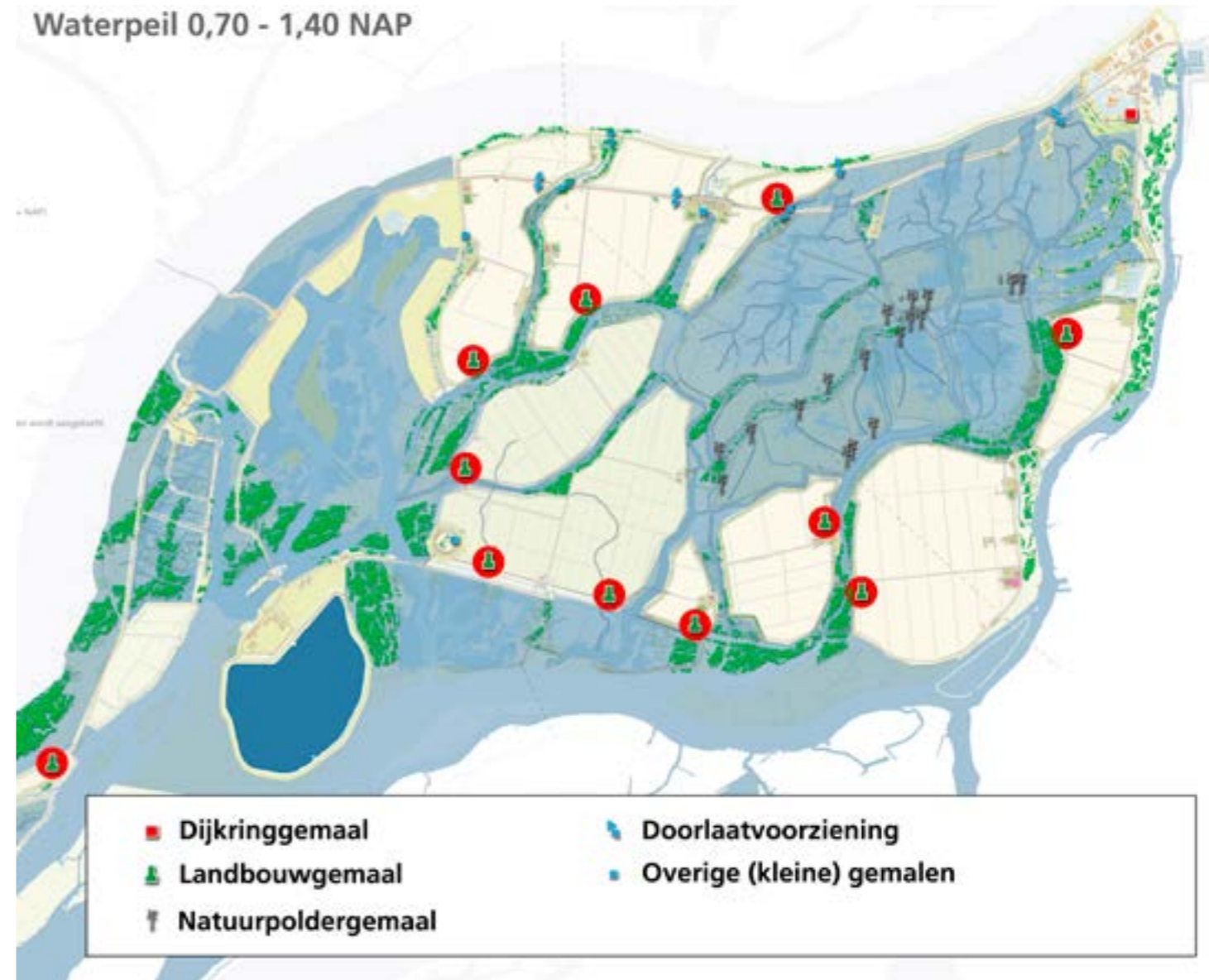

kunstwerken Noordwaard > uitgangspunten ontwerp

- overstroombaar, wisselend waterpeil
- passend bij groots, desolaat landschap
- afleesbare constructie / opbouw
- hoogwaardige beeldkwaliteit / vormfamilie

kunstwerken Noordwaard > familie

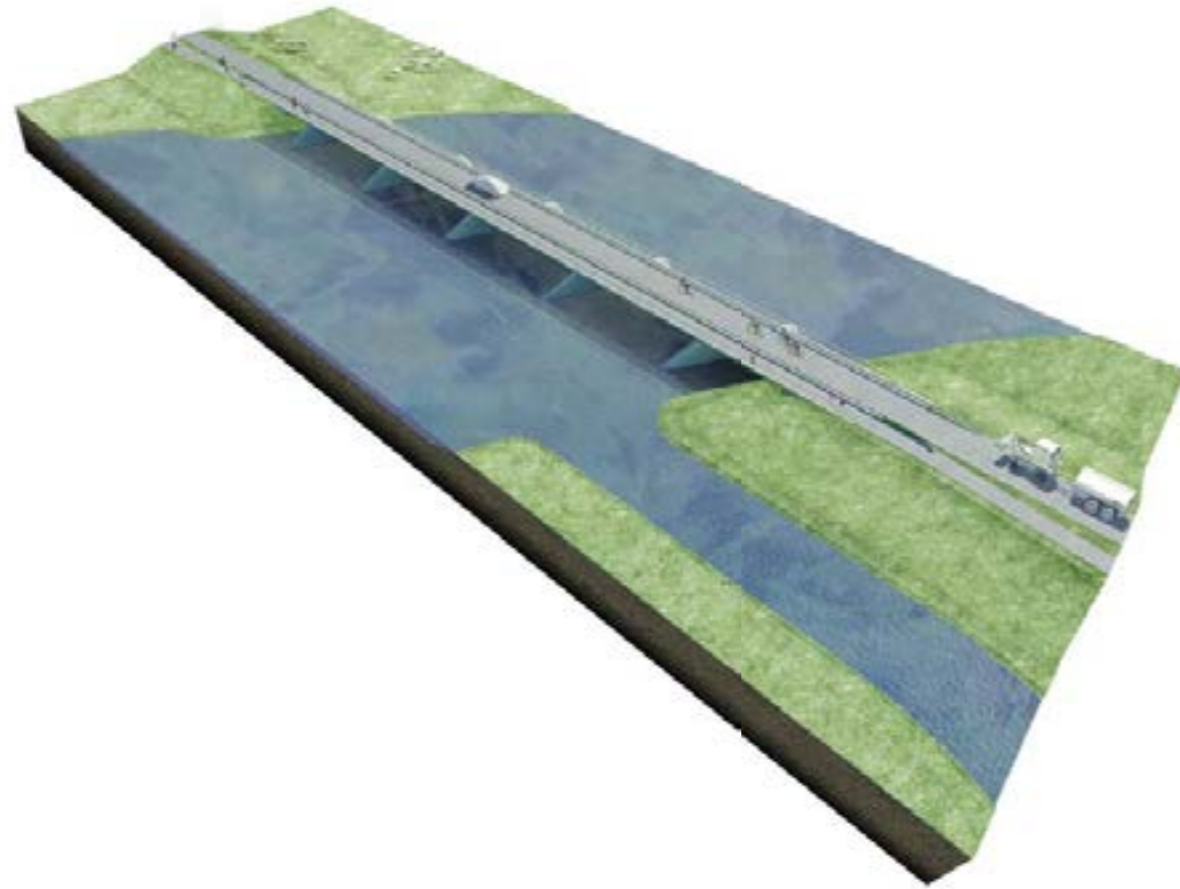

DIJKBRUGGEN

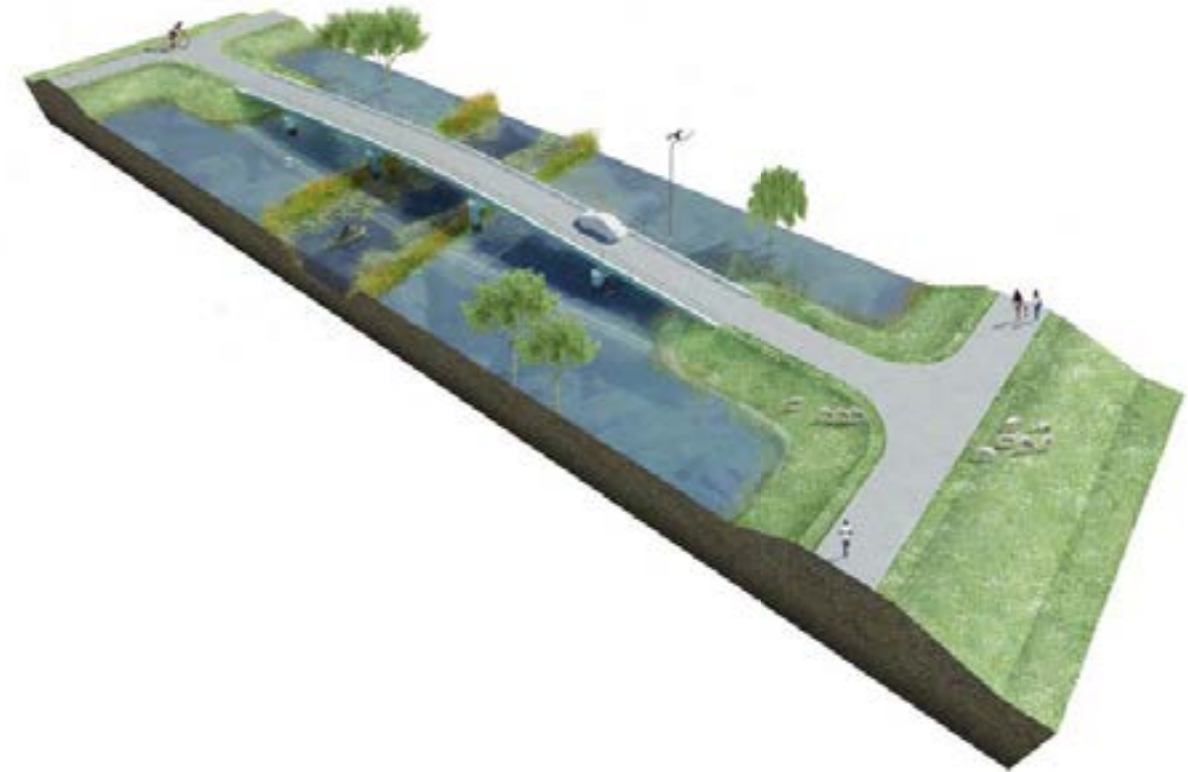

KREEKBRUGGEN

kunstwerken Noordwaard > familie



STEURGATBRUGGEN

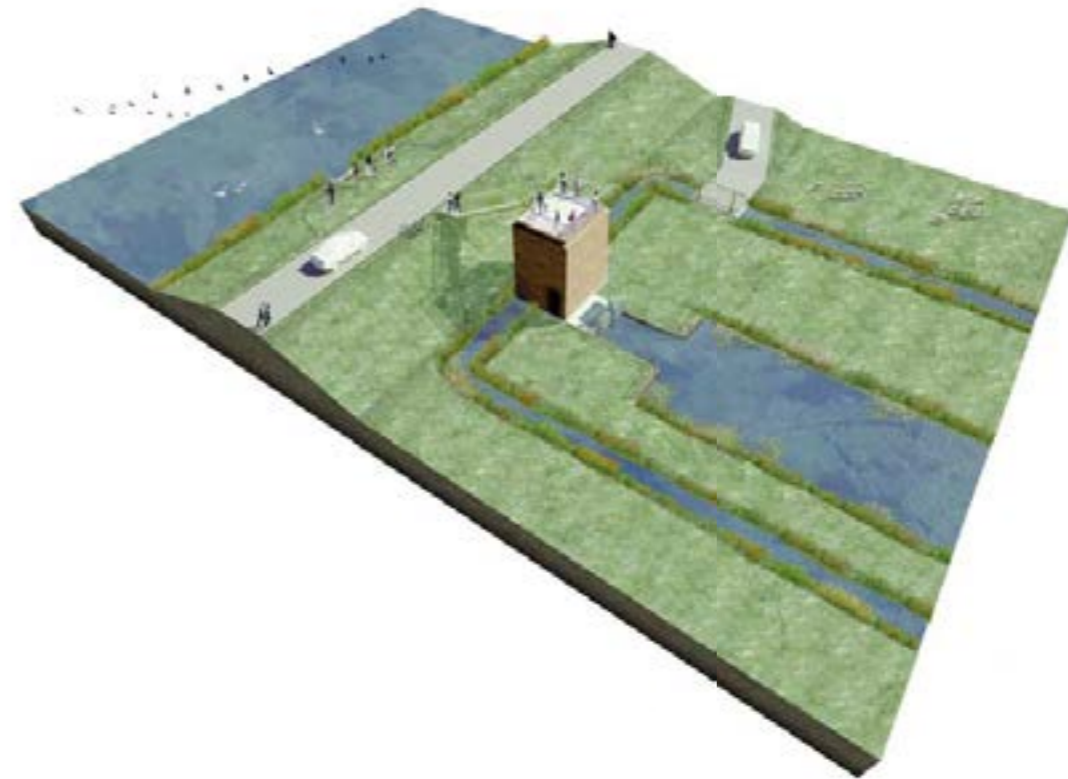

GEMAALGEBOUWEN

kunstwerken Noordwaard > dijkbruggen



kunstwerken Noordwaard > kreekbruggen



kunstwerken Noordwaard > steurgatbruggen



kunstwerken Noordwaard > gemaalgebouwen



kunstwerken Noordwaard > plankiers



kunstwerken Noordwaard > details



Leeuwarden, Zuidlanden



Leeuwarden, Zuidlanden



Leeuwarden, Zuidlanden > uitgangspunten

- bruggenstandaard voor diverse buurtschappen
- inpasbaar maken van een veeltal type aanlandingen
- kostenefficiënt, sober
- duurzaam

Leeuwarden, Zuidlanden > visie

- Inspiratie Friese landschap
- Praktische en nuchtere ontwerpbenadering.
- De Zuidlanden; eigen karakter, landschappelijke en architectonische kenmerken

' praktische soberheid, eenvoud en een herkenbaar silhouet '

Leeuwarden, Zuidlanden

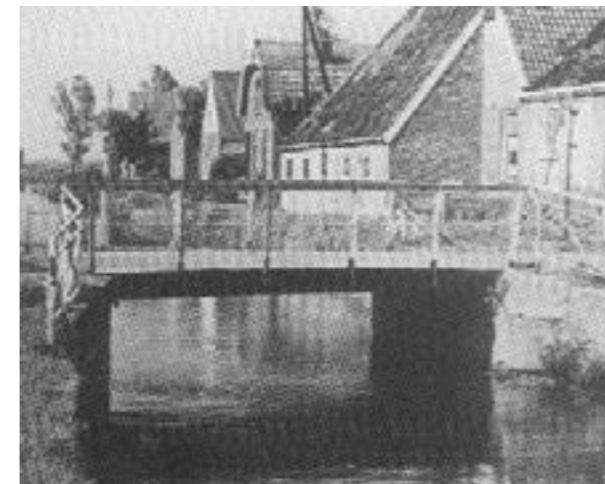

Leeuwarden, Zuidlanden > Bouwstenen

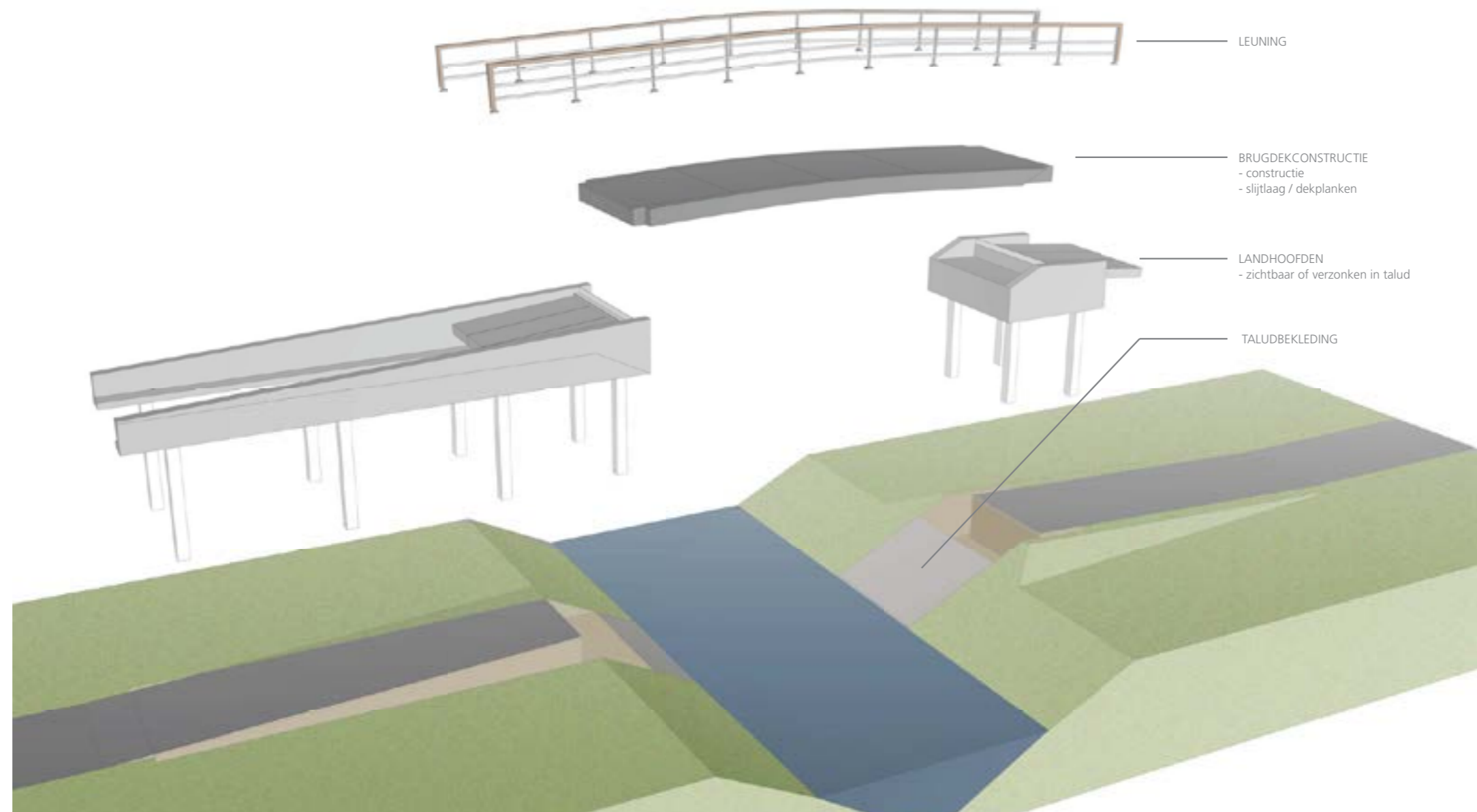

Leeuwarden, Zuidlanden



Leeuwarden, Zuidlanden



Leeuwarden, Zuidlanden



Leeuwarden, Zuidlanden



Leeuwarden, Zuidlanden

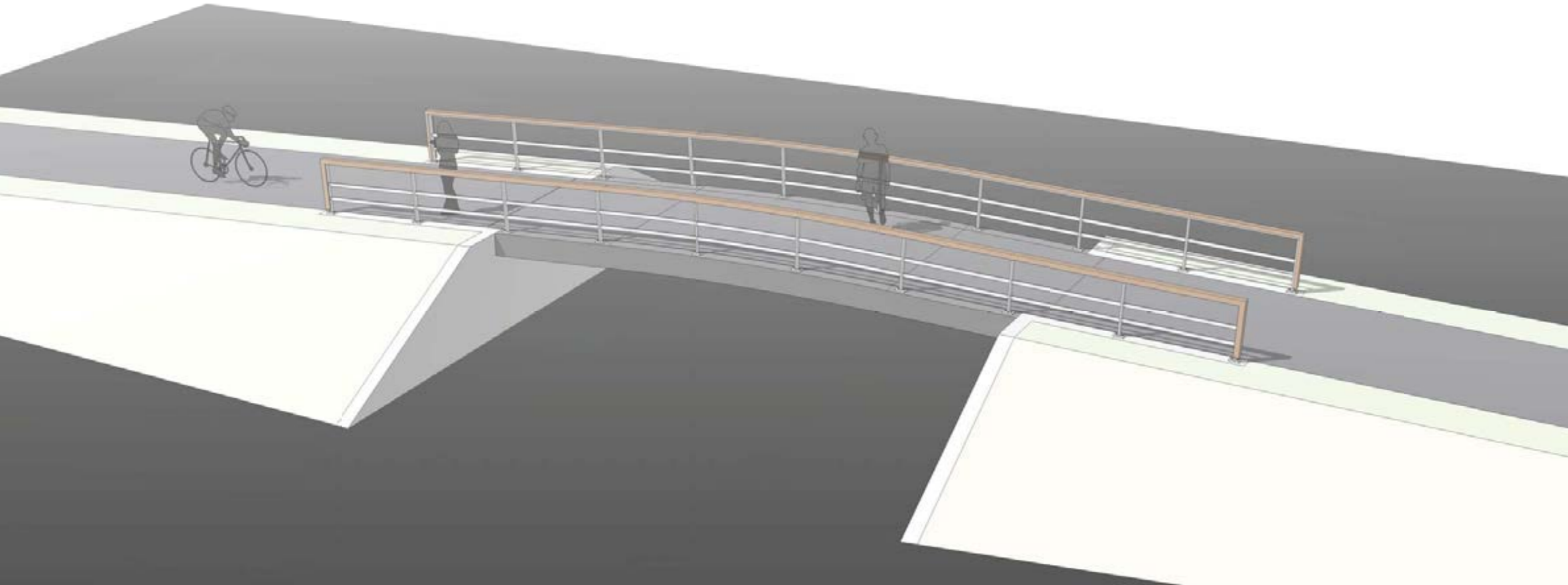

Leeuwarden, Zuidlanden



Leeuwarden, Zuidlanden



BETON GRIJSSCHAAL-II



KLEUR STALEN BRUGDEKCONSTRUCTIE EN STEUNPUNT RAL7011, IJZERGRIJS

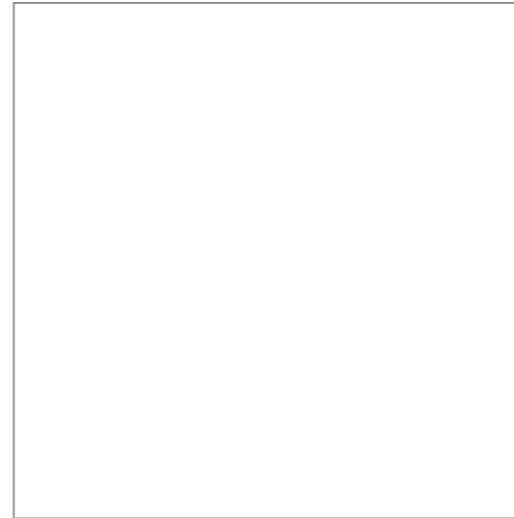

KLEUR STALEN LEUNING RAL 9016, VERKEERSWIT



LEUNING



HARDHOUT



VERDUURZAAMD HOUT



DETAIL HANDREGEL

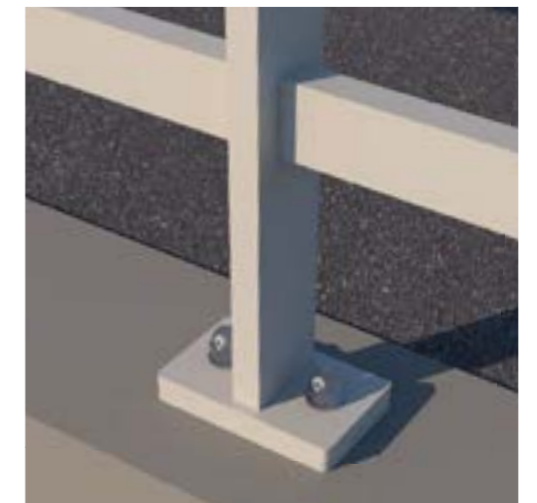

DETAIL VOETPLAAT

Leeuwarden, Zuidlanden > duurzaamheid

LH-1



LH-2



Leeuwarden, Zuidlanden > duurzaamheid

- LEW.12-LH1-beton
- IFW.12-IH1-staal
- IFW.12-IH1-hout-azobe
- IFW.12-IH1-hout-zacht
- IFW.12-IH1-composiet
- LEW.12-LH2-beton
- LEW.12-LH2-staal
- LEW.12-LH2-hout-azobe
- LEW.12-LH2-hout zacht
- LEW.12-LH2-composiet



Bedankt voor uw aandacht

Graag werken wij met u samen aan
mooie, slimme en duurzame oplossingen